

An assessment of context-specificity of the CS-preexposure effect in Pavlovian excitatory and inhibitory conditioning

Sadahiko Nakajima^{a,*}, Kosuke Takahashi^a, Aaron P. Blaisdell^b

^a *Kwansei Gakuin University, Nishinomiya, Japan*

^b *University of California, Los Angeles, USA*

Received 11 August 2005; received in revised form 22 March 2006; accepted 23 March 2006

Abstract

Non-reinforced preexposure to a to-be-conditioned stimulus (CS) results in retarded development of conditioned excitation and inhibition. In a magazine-approach preparation in rats, we explored the role of background context on this CS-preexposure effect by changing contexts after the preexposure treatment. Experiment 1 demonstrated with a typical three-group design that changing background contexts attenuated the CS-preexposure effect in conditioned excitation. Experiment 2 employed the identical design except that conditioned inhibition was the target of study. Preexposure to stimulus X retarded subsequent differentiation of responding to reinforced A trials and non-reinforced AX trials, suggesting that CS-preexposure retarded development of inhibitory conditioning. However, changing contexts did not attenuate the preexposure effect. We discuss these results in the framework of the extended comparator hypothesis.

© 2006 Elsevier B.V. All rights reserved.

Keywords: CS-preexposure effect; Latent inhibition; Conditioned excitation; Conditioned inhibition; Context; Rats

1. Introduction

Non-reinforced preexposure to a to-be-conditioned stimulus (CS) results in retarded development of conditioning (see Hall, 1991; Lubow, 1973, 1989; Weiss and Brown, 1974, for reviews). This effect has been called latent inhibition, or simply, the CS-preexposure effect. A large number of studies on the CS-preexposure effect with laboratory rats as subjects have demonstrated retarded development of excitatory conditioning in both appetitive (conditioned approach: e.g., Baker and Mackintosh, 1977; Channell and Hall, 1983; Kaye et al., 1987; McLaren et al., 1994; Reed, 1991, 1995; Rosas and Bouton, 1997) and aversive (conditioned suppression: e.g., Baker and Mercier, 1982; Blaisdell et al., 1998; Kremer, 1972; Hall and Minor, 1984; Lovibond et al., 1984; Lubow and Siebert, 1969; Rescorla, 1971; conditioned taste aversion: e.g., Aguado et al., 1994; Fenwick et al., 1975; Hall and Channell, 1986; Kiefer et al., 1977; Nakajima et al., 1999; Revusky and Bedarf, 1967;

Siegel, 1974) preparations. Preexposure to a CS also retards the development of inhibitory conditioning in both appetitive (conditioned approach: Baker and Mackintosh, 1977) and aversive (conditioned suppression: Friedman et al., 1998; Rescorla, 1971) preparations (see also Reiss and Wagner, 1972, for evidence using eyelid conditioning in the rabbit).

A feature of the CS-preexposure effect is that a context change between preexposure and excitatory conditioning disrupts the effect. The context-specificity of the CS-preexposure effect has been demonstrated in both appetitive (conditioned approach: e.g., Channell and Hall, 1983; Hall and Channell, 1985; Kaye et al., 1987; McLaren et al., 1994; Rosas and Bouton, 1997) and aversive (conditioned suppression: e.g., Hall and Honey, 1989; Hall and Minor, 1984; Lovibond et al., 1984; conditioned taste aversion: e.g., Hall and Channell, 1986) preparations, and serves as a critical test for several accounts of the CS-preexposure effect (e.g., Bouton, 1991, 1993; Wagner, 1976, 1981).

As far as we know, nevertheless, there are no published studies concerning context-specificity of the CS-preexposure effect on inhibitory conditioning. Hence, the present study focused on this issue. Table 1 shows the designs of the two experiments. Experiments 1 and 2 explored context-specificity of the CS-preexposure effect with between-subject designs. Each

* Corresponding author at: Department of Psychology, Kwansei Gakuin University, Nishinomiya, Hyogo 662-8501, Japan. Tel.: +81 798 54 6076; fax: +81 798 54 6076.

E-mail addresses: nakajima@kwansei.ac.jp, cs-us@nifty.com (S. Nakajima).

Table 1
The designs of experiments 1 and 2

Groups	Preexposure	Magazine	Conditioning	Test
Experiment 1: excitatory conditioning test				
Pre-same	1: X-, 2: ---	1: +	1: A+	1: X+
Pre-diff	1: ---, 2: X-			
Control	1: ---, 2: ---			
Experiment 2: inhibitory conditioning test				
Pre-same	1: X-, 2: ---	1: +	1: A+	1: A+, AX-
Pre-diff	1: ---, 2: X-			
Control	1: ---, 2: ---			

Notes: A: illumination of a disk on the panel; X: a buzzer tone; +: sucrose solution US, -: no US; ---: context exposure. Numbers to the left of the colon denote context (1 or 2) in which treatment (to the right of the colon) was given.

experiment consisted of three groups of rats: groups pre-same and pre-diff were preexposed to a buzzer tone (X) in contexts 1 and 2, respectively, while group control received no buzzer tone in either context. The two experiments were identical in their procedure prior to testing. In testing, excitatory (experiment 1) or inhibitory (experiment 2) conditioning with the buzzer tone was assessed in context 1 for all rats.

2. Experiment 1

The purpose of experiment 1 was to demonstrate context-specificity of the CS-preexposure effect on excitatory appetitive conditioning. Although the literature has reported the phenomenon as noted in the introduction, its replication with our procedure was critical in order to compare the results of experiment 1 with those of experiment 2.

2.1. Method

2.1.1. Subjects

The subjects were 24 experimentally-naïve male Wistar rats obtained from a local supplier. The animals were housed in individual hanging home cages on a 12:12 light–dark cycle (lights on at 8:00) at about 23 °C and maintained at 85% of their free-feeding weights. The rats were approximately 60 days old at the beginning of the experiment and split into three groups of equal number ($n=8$ each). Water was always available in the home cages. Care and maintenance were conducted in accordance with the national guidelines.

2.1.2. Apparatus

Four modular rat chambers (ENV-007CT, MED Associates, USA), measuring 32 cm long, 24 cm wide, and 29.5 cm high, were housed in individual sound-attenuating shells. Each chamber was made of metal front and back panels, clear acrylic sidewalls, a metal ceiling, and a grid floor consisting of metal rods (4 mm in diameter) spaced 16 mm apart center to center. A 3 W light bulb was centered 27 cm above the floor, and it was employed as a houselight. A metal casing of the bulb directed the light to the ceiling. Two circular light disks (25 mm in diameter) were also located on the front panel 144 mm above the floor and 25 mm from the nearby sidewall. A 5 cm × 5 cm magazine

opening was located on the center of the front panel. Its bottom edge was 15 mm above the floor, and sucrose solution could be presented there via a 0.1 ml dipper cup. From these chambers, two contexts were made that differed in visual and tactile cues (cf. Nakajima et al., 2000). One context had a 25 cm metal chain suspended from the center of the ceiling. A black acrylic plate covered the grid floor, and the houselight was always off. The other context had a white acrylic wall tilted against the back panel, making a smaller room space of 18 cm × 24 cm on base. The houselight was illuminated throughout the sessions. These two contexts were fully counterbalanced across rats as contexts 1 and 2. The stimulus cues employed as CS A and CS X, respectively, were illumination of the left circular disk (2.8 W) and a low-pitch buzzer tone from an electric buzzer (SMB-24, Kamada Signal Application, Japan) on the wall of each outer shell. The sound level of the buzzer was 71 dB (re Scale C) against the background level of 66 dB. The biologically significant or unconditioned stimulus (US) was delivery of 30% (w/w) sucrose solution. Entries into the magazine opening (i.e., goal-tracking behavior) were measured as conditioned responses by an infrared photo beam system located 10 mm inside the opening. The experiment was controlled and the data were recorded by a MED-PC system that was interfaced to a microcomputer.

2.1.3. Procedure

Throughout this and the following experiment, sessions were scheduled on successive days, 7 days a week, at the same time each day (around the midpoint of the light period). Supplemental feeding was given after each session to maintain the rats' body weights. The experimental design is presented in Table 1.

The preexposure phase consisted of four sessions each in contexts 1 and 2: each session lasted for 34 min, and the order of two contexts across 8 days was 12212112 for half of the rats of each group and 21121221 for the other half. Rats of group pre-same were exposed to a 5 s buzzer tone (X-) 24 times per session with the mean intertrial interval (ITI) of 80 s (range: 40–120 s) in context 1, while those of group pre-diff received the same treatment in context 2. The third group of rats (group control) received no programmed experimental events in either context.

On the next day, all rats received magazine training in context 1. The session began with a 20 s presentation of the dipper cup containing 0.1 ml sucrose in the magazine opening, and it was followed by 5 s presentations of the same dipper cup with a variable interval of 30 s until the cumulative number of accessed trials reached 20. As one animal of group pre-diff failed to acquire magazine behavior, it was excluded from the experiment.

On the next 4 days, each rat was given excitatory conditioning to the panel light in context 1. A trial consisted of 5 s illumination of the light followed by 5 s presentation of sucrose solution (A+). Twenty-four trials with a mean ITI of 80 s were presented in each daily session. This phase was irrelevant to demonstration of the CS-preexposure effect on excitatory conditioning with buzzer, but it was included in this experiment in order to match the procedural details to those of experiment 2.

Testing of the target buzzer tone was administered for 8 days in context 1. Each session consisted of 12 trials of the 5 s buzzer followed by 5 s sucrose presentation (X+) intermixed with 12 dummy-trial intervals of 5 s. The mean ITI was 80 s. The dummy intervals were employed here to match the mean buzzer-to-buzzer and sucrose-to-sucrose intervals equal to those of experiment 2.

2.1.4. Analysis

Throughout the experiment, the data collected were photocell counts during individual trials of the buzzer or light stimulus. The photocells were polled every 1 s of the trials, and the counts were cumulated over each session. Also recorded were responses during an equal number of randomly selected baseline periods of the same duration (i.e., 5 s). As there were no statistically reliable group effects on the baseline data throughout the study, the difference score (trial performance minus baseline performance) was employed for all analyses. In statistical tests including post-hoc analyses by Fisher's LSD procedure, the significance level was set at $P < 0.05$.

2.2. Results and discussion

There were no group effects in the excitatory conditioning of the panel light (A+). A group \times session analysis of variance (ANOVA) yielded a significant main effect of session, $F(3, 60) = 157.25$, $P < 0.001$, but the main effect of group, $F < 1$, and the group \times session interaction, $F(6, 60) = 1.18$, were non-significant. The difference score (per 5 s trial) averaged over all rats was -0.29 on the first session and it increased to 1.88 on the final session. The value below zero on the first conditioning session suggests an unconditioned suppressive effect of a novel light stimulus. A paired t -test applied to the baseline and light trial data confirmed the light's suppressive effect in the first session, $t(22) = 3.20$, $P < 0.005$.

As shown in Fig. 1, we observed a reliable CS-preexposure effect and the effect was small in the rats tested in the context different from that of preexposure: group pre-same acquired conditioned magazine entries slower than group control, and the performance of group pre-diff located between them. These impressions were supported by a group \times session ANOVA, which yielded a significant main effect of session, $F(7, 140) = 12.14$, $P < 0.001$, and its interaction with the group factor, $F(14, 140) = 1.88$, $P < 0.05$. The main effect of group, $F(2, 20) = 1.73$, was not significant. A post-hoc analysis of the interaction revealed significant group differences as follows: group pre-same scored lower than group control (i.e., the CS-preexposure effect) in all sessions except session 7, while group pre-diff scored better than group pre-same (i.e., context-specificity of the CS-preexposure effect) in sessions 3, 4, 6 and 7. In addition, group pre-diff scored lower than group control (i.e., imperfect context specificity) only in sessions 1 and 8.

Because of the large score shown in the first session of group control, one might suspect immediate cross-modal generalization from the panel light, which had been conditioned prior to testing, to the buzzer tone in this group. This was not the case. Fig. 2 details the acquisition of conditioned maga-

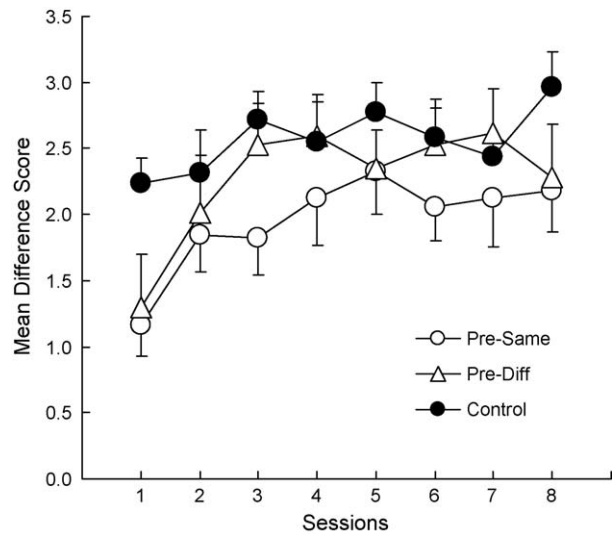

Fig. 1. Excitatory conditioning of a buzzer tone (X) in the test of experiment 1. The index was the difference score between the responses during the X+ trials and those of the baseline periods. Groups pre-same and pre-diff received preexposure to X in contexts 1 and 2, respectively, while group control was exposed to both contexts without presentations of X. Testing was administered in context 1 for all rats. Bars of standard errors are shown on either side for simplicity.

zine entries in the first test session. All groups started from an equivalent low level of performance: a one-way ANOVA on the first two-trial block found no group difference, $F(2, 20) = 1.05$. Thereafter, group control outpaced the other groups. A two-way ANOVA applied to the remaining five blocks yielded significant main effects of group, $F(2, 20) = 5.65$, $P < 0.05$, and Block, $F(4, 80) = 3.31$, $P < 0.05$, but their interaction was not significant, $F < 1$. Subsequent analysis of the main effect of group revealed that group control surpassed groups pre-same and pre-diff, which did not differ from each other.

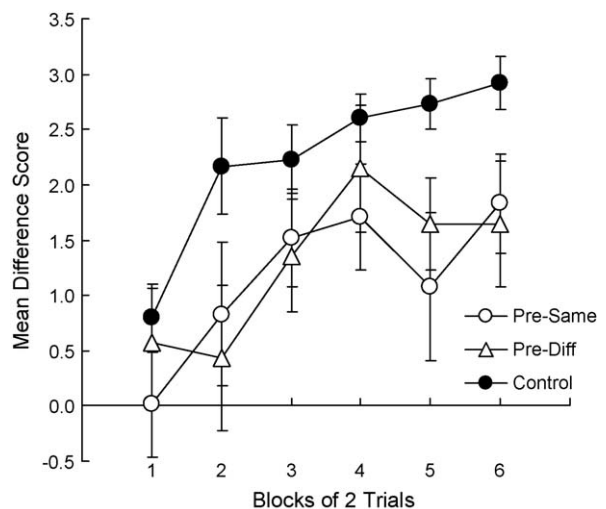

Fig. 2. Difference scores for the first test session in experiment 1. The difference score was calculated on the basis of blocks of two trials. Bars of standard errors are shown on both sides.

3. Experiment 2

Experiment 1 demonstrated the CS-preexposure effect and its context-specificity in excitatory conditioning of a buzzer tone. Experiment 2 explored the same issues but in inhibitory conditioning of the same stimulus. To our knowledge, there are no published studies on the context-specificity of the CS-preexposure effect on inhibitory conditioning. In experiment 2, we employed Pavlov's conditioned inhibition procedure (i.e., simultaneous feature-negative discrimination training: A+, AX−) as in other studies examining the CS-preexposure effect on inhibitory conditioning (Baker and Mackintosh, 1977; Rescorla, 1971; Reiss and Wagner, 1972; but see Friedman et al., 1998).

3.1. Method

3.1.1. Subjects and apparatus

The subjects were 24 experimentally-naive male Wistar rats that were 60 days old and were maintained in the same manner as the rats used in experiment 1. The apparatus and other contextual cues were identical to those of experiment 1.

3.1.2. Procedure

The procedure was identical to that of experiment 1 except for testing (Table 1). In the test sessions, 12 trials of the 5 s panel light immediately followed by 5 s sucrose delivery (A+) were randomly mixed with 12 non-reinforced compound trials of the panel light and the buzzer tone (AX−). The light and the buzzer occurred simultaneously in the 5 s compound trials. The mean ITI was 80 s, and the test sessions lasted for 5 days.

3.2. Results and discussion

Excitatory conditioning of the panel light (A+) proceeded smoothly. A group \times session ANOVA failed to find a main effect of group, $F < 1$, but revealed a main effect of session, $F(3, 63) = 247.18$, $p < 0.001$. Although the group \times session interaction attained significance, $F(6, 63) = 2.76$, $p < 0.05$, subsequent analyses failed to reveal any significant group differences in any sessions. Thus, we treated it as a random fluctuation of the data. The difference score averaged over all rats was -0.35 on the first session and it increased to 2.14 on the final session. As in experiment 1, the value of the first session was below zero, suggesting an unconditioned suppressive effect of the novel light stimulus: a paired t -test applied to the baseline and light trial data confirmed the light's suppressive effect in the first session, $t(23) = 3.90$, $p < .001$.

The test performance is shown in the top panel of Fig. 3. The inhibitory conditioning of the buzzer (X), as reflected in lower responding on the light-buzzer compound trials (AX−) than on the light-only trials (A+), was established in all groups but its speed differed among the groups. On average, group control acquired conditioned inhibition faster than groups pre-same and pre-diff. A group \times trial type \times session ANOVA applied the data summarized in this panel yielded significant main effects of trial type, $F(1, 21) = 23.67$, $P < 0.001$, and session, $F(4, 84) = 9.32$, $P < 0.001$. More importantly, there were significant interactions

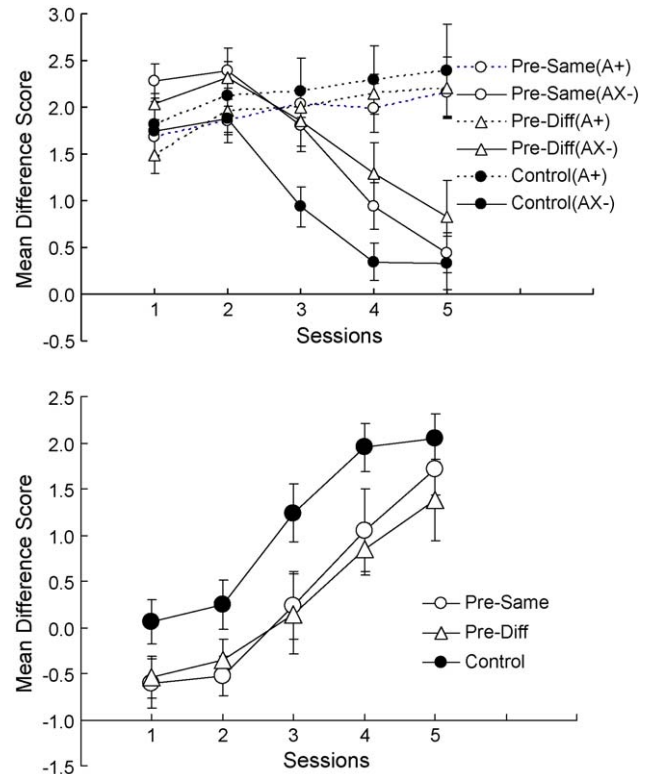

Fig. 3. Inhibitory conditioning to the buzzer tone (X) in the test of experiment 2. Top panel: the difference score between the responses during the A+ or AX− trials and those of the baseline periods. Bottom panel: the difference score between the responses during the A+ trials and those of the AX− trials. Groups pre-same and pre-diff received preexposure to X in contexts 1 and 2, respectively, while group control was exposed to both contexts without presentations of X. Testing was administered in context 1 for all rats. Bars of standard errors are shown on both sides.

of group \times trial type, $F(2, 21) = 4.54$, $P < 0.05$, and trial type \times session, $F(4, 84) = 49.19$, $P < 0.001$. The main effect of group and the other interactions were non-significant, $F_s < 1$.

There were no group differences in responding on the reinforced light-only trials (A+). A group \times session ANOVA applied to the difference scores of the light-only trials yielded a significant main effect of session, $F(4, 84) = 6.36$, $P < 0.05$, but the main effect of group and its interaction with session were not significant, $F_s < 1$.

The three groups differed in their performance on the light-buzzer compound trials (AX−), and inhibitory conditioning of the buzzer tone was indexed by the difference in responding on the two types of trials: the responding on the light-buzzer compound trials (AX−) was subtracted from the responding on the light-only trials (A+). As shown in the bottom panel of Fig. 3, acquisition of inhibitory conditioning is reflected in the increasing curves of all groups. This graph also revealed a reliable CS-preexposure effect but no context-specificity. In other words, retardation of acquisition of inhibitory conditioning, with respect to group control, was equivalent between groups pre-same and pre-diff. These impressions were supported by a group \times session ANOVA, which yielded significant main effects of group, $F(2, 21) = 4.54$, $P < 0.05$, and session, $F(4, 84) = 49.19$, $P < 0.001$ and a non-significant group \times session interaction, $F < 1$.

(note that these values, respectively, correspond to the values of the group \times trial type interaction, the trial type \times session interaction, and the group \times trial type \times session interaction in the above-noted three-factor ANOVA applied to the data summarized in the top panel of Fig. 3). A post-hoc analysis of the group effect revealed that group control showed significantly better performance than groups pre-same and pre-diff, which did not differ from each other. The failure of detecting context-specificity of CS preexposure on inhibitory conditioning cannot be simply ascribed to the power of the statistical test employed here, as average performance was numerically worse in group pre-diff than group pre-same.

4. General discussion

Two experiments with rats explored context-specificity of the CS-preexposure effect on appetitive conditioning with magazine approach behavior as the conditioned response. Experiment 1, employing a between-groups design, demonstrated both the CS-preexposure effect and its context-specificity in excitatory conditioning. These results accord with the literature in appetitive (e.g., Channell and Hall, 1983; Hall and Channell, 1985; Kaye et al., 1987; McLaren et al., 1994; Rosas and Bouton, 1997) and aversive (e.g., Hall and Honey, 1989; Hall and Minor, 1984; Lovibond et al., 1984) preparations. Experiment 2, also employing a between-group design, successfully demonstrated the CS-preexposure effect on inhibitory conditioning as in the previous research in appetitive (Baker and Mackintosh, 1977) and aversive (Friedman et al., 1998; Rescorla, 1971) preparations. However, there was no context-specificity in experiment 2. One may argue that the CS-preexposure effect on inhibitory conditioning would be context specific, if we had employed other methods (e.g., using more dissimilar contexts). We admit this possibility, but it must be remembered that the animals in experiment 2 received exactly the same treatments as those in experiment 1 except for the fact that an inhibitory, rather than excitatory, conditioning test was administered in experiment 2. Thus, it is reasonable to conclude that it is harder, if not impossible, to detect context-specificity of the CS-preexposure effect on inhibitory conditioning than on excitatory conditioning.

In the animal learning literature, several theories have been proposed for the CS-preexposure effect: loss of attention (Mackintosh, 1975), loss of associability (Pearce and Hall, 1980), CS-no event association (Hall et al., 1985), conditioned inattention (Lubow, 1989; Lubow et al., 1981), priming by context (Wagner, 1976, 1981), and retrieval failure (Bouton, 1991, 1993). Some of them successfully account for the context-specificity of the CS-preexposure effect (Bouton, 1991, 1993; Wagner, 1976, 1981). However, none of them make direct predictions of our demonstrated asymmetry in context-specificity between excitatory and inhibitory conditioning.

An exception is the extended comparator hypothesis (Blaisdell et al., 1998; Denniston et al., 2001), which does predict that a context switch between preexposure and conditioning will disrupt the CS-preexposure effect in conditioned excitation, but not in conditioned inhibition using the Pavlovian procedure. The comparator hypothesis is a qualitative response rule for the

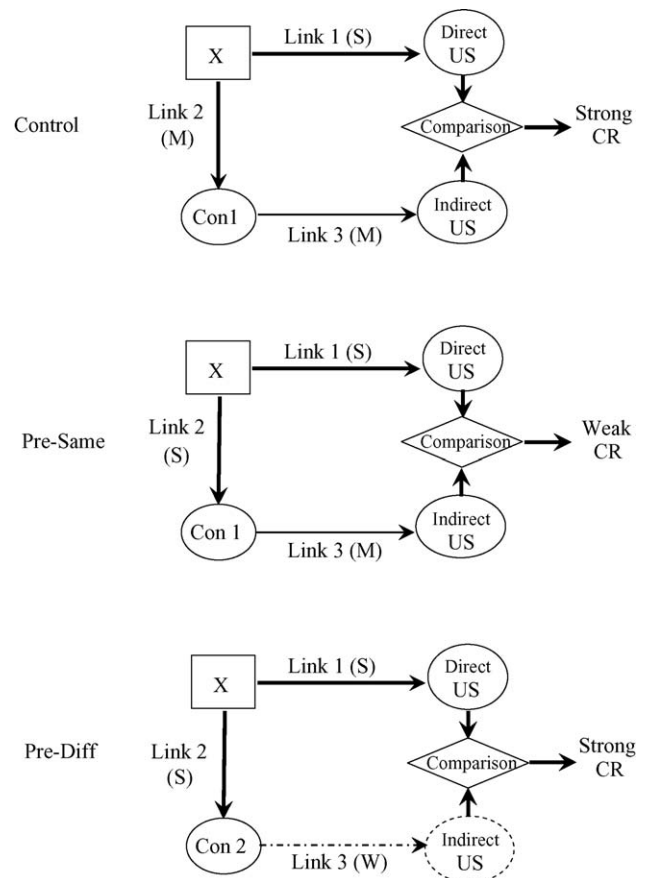

Fig. 4. Diagrams depicting the architecture of the comparator hypothesis for the tests on X as applied to each group of experiment 1. Con 1 and Con 2: contexts 1 and 2, respectively. W: weak or no association, M: moderate strength association, S: strong association. Thickness of arrows for links 1–3 indicate associative strength as follows: dashed line: weak or no association, thin solid line: moderate association, and a thick solid line: strong association. “Direct US”: the direct pathway (link 1) through which the US representation is activated; “Indirect US”: the indirect pathway (product of links 2 and 3) through which the US representation is activated. The thickness of the US representation bubble indicates a weakly (dashed line), moderately (thin solid line) or strongly (thick solid line) activated US representation. CR: conditioned response.

expression of acquired Pavlovian associations. In the framework of the comparator hypothesis as originally stated by Miller and Matzel (1988) and Miller and Schachtman (1985), conditioned responding reflects a comparison between the US representation activated directly through the target CS-US association (link 1 in Figs. 4 and 5) and the US representation activated indirectly through the product of the target CS-comparator stimulus (link 2) and comparator stimulus-US (link 3) associations. The target stimulus is the stimulus presented at test (e.g., X), and the comparator stimulus for the CS is the stimulus with which the target stimulus has the strongest association (other than the US). Excitatory responding to the target CS increases with the strength of the directly-activated US representation, and decreases with the strength of the indirectly-activated US representation. Conversely, inhibitory responding to the target inhibitor decreases with the strength of the directly-activated US representation, and increases with the strength of the indirectly-activated US representation.

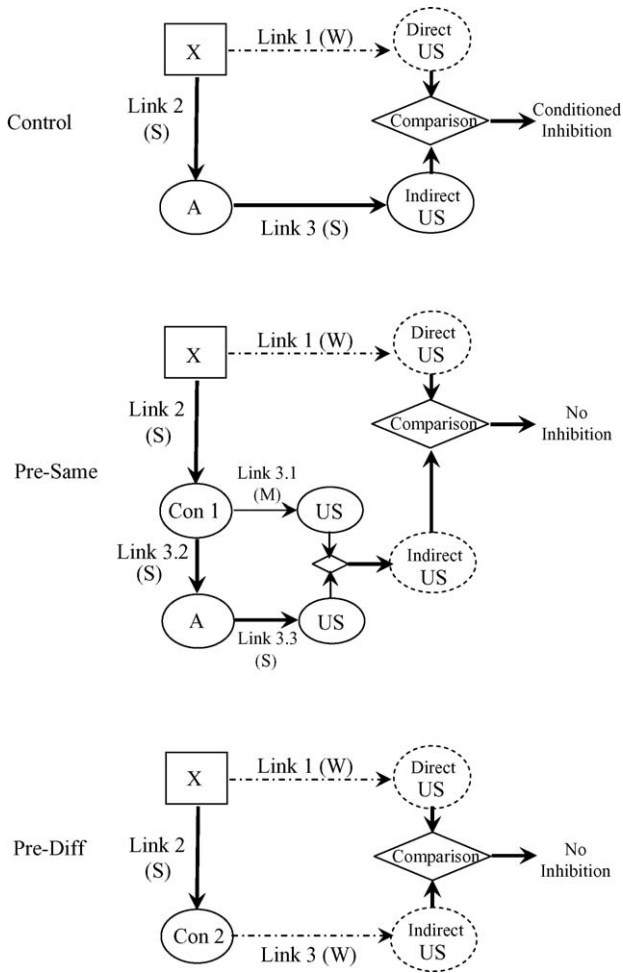

Fig. 5. Diagrams depicting the architecture of the comparator hypothesis for the tests on X as applied to each group of experiment 2. Con 1 and Con 2: contexts 1 and 2, respectively. W: weak or no association, M: moderate strength association, S: strong association. Thickness of arrows for links 1–3 indicate associative strength as follows: dashed line: weak or no association, thin solid line: moderate association, and a thick solid line: strong association. “Direct US”: the direct pathway (link 1) through which the US representation is activated; “Indirect US”: the indirect pathway (product of links 2 and 3) through which the US representation is activated. The thickness of the US representation bubble indicates a weakly (dashed line), moderately (thin solid line) or strongly (thick solid line) activated US representation.

In experiment 1, the context is the stimulus with the strongest association with target CS X. According to the comparator hypothesis, the CS-preexposure effect results from a stronger X-context association (link 2) in the group that received preexposure to X in context 1 (Fig. 4, middle panel) than in the control group (Fig. 4, top panel). The stronger X-context association increases the strength of the indirectly activated US representation relative to the control group, thereby allowing context 1 to better down modulate excitatory responding to X. The reason stronger excitatory responding is observed in group pre-diff than in group pre-same is because, though a strong X-context 2 association is established during preexposure (link 2), no association is subsequently formed between context 2 and the US (link 3), leading to an extremely weak or non-existent indirectly-activated US representation (see Fig. 4). Thus, context

2 should not be able to down modulate excitatory responding to X. It might be noteworthy that these accounts also predict stronger responding in group pre-diff than group control, which was incongruent with the results of experiment 1. Comparator theory predicts this only if contexts 1 and 2 are completely discriminable. The data in Figs. 1 and 2 show that a context shift attenuated, but did not completely abolish the preexposure effect. This suggests that the contexts were not completely discriminable, and thus the theory does not predict stronger excitatory responding in group pre-diff than in group control.

The extended comparator hypothesis makes a different prediction regarding the effects of a context switch on the expression of Pavlovian conditioned inhibition to X (see also Friedman et al., 1998). (The extended comparator hypothesis does, however, make the same prediction as the original comparator hypothesis regarding a context switch upon CS-preexposure effect on conditioned excitation). The source of this difference is that the extended comparator hypothesis posits that each link of the indirect pathway to the US representation (i.e., links 2 and 3) is modulated by its own comparator stimulus. Fig. 5 shows how the extended comparator hypothesis is applied to experiment 2. In group control, there are two potential comparator stimuli for X; these are CS A and the training context (which happens to be context 1). CS A is a discrete stimulus, and thus is more salient than the continuously present background context 1. Furthermore, CS A has a much higher contiguity to CS X than does context 1, due to the fact that the ratio of [Context 1:~X/Context 1:X] (the context in the absence vs. in the presence of X, respectively) is much higher than the ratio of [A:~X/A:X] (A in the absence versus in the presence of X, respectively). Thus, A serves as the primary comparator stimulus for X (see Blaisdell et al., 1999, for a discussion of variables that influence competition among comparator stimuli). Because A has a strong association with the US while X had never been paired with the US, the indirectly-activated US representation (the product of links 2 and 3) will be much stronger than the directly-activated US representation (link 1; Fig. 5, top panel). By contrast, preexposure to X in context 1 greatly increases the strength of the X-context 1 association, which establishes context 1 as the most effective comparator stimulus for X (Fig. 5, middle panel). However, in the framework of the extended comparator hypothesis, the effectiveness of a comparator stimulus in modulating the response to the target stimulus is itself modulated by its own comparator stimuli (with the rule that the target CS cannot also serve as a higher-order comparator stimulus). In group pre-same, A will serve as the comparator stimulus for context 1 as a result of their pairings during conditioning. The moderate context 1-US association (link 3.1) is thus down modulated by the strong A-US association (link 3.3), thereby attenuating the indirectly-activated US representation (Fig. 5, middle panel). Thus, Pavlovian conditioned inhibition should be much weaker in group pre-same than in group control. Group pre-diff should also show attenuated Pavlovian conditioned inhibition, but for a different reason than should group pre-same. In group pre-diff, preexposure to X in context 2 should establish that context as the primary comparator stimulus for X (link 2, Fig. 5, bottom panel). Because the US is never subsequently presented in context 2, no con-

text 2-US association should develop (link 3). Thus, the strong indirectly-activated US representation needed to down modulate responding to X is non-existent, resulting in no conditioned inhibition to X.

Hence, the extended comparator hypothesis fits with the data we presented here, although this study was not planned to test the extended comparator hypothesis. Continuing investigations, examining both the generality of the results we presented here and the validity of the extended comparator hypothesis, are necessary to delineate the CS-preexposure effect and the roles of the contexts. Furthermore, our assessment of the context-specificity of CS preexposure on inhibitory conditioning was based upon the trainability of the preexposed CS as a feature cue to signal non-reinforcement in Pavlov's conditioned inhibition procedure (i.e., simultaneous feature-negative discrimination training: A+, AX–). Summative transfer and retardation of acquisition tests of conditioned inhibition are desirable in future research.

Acknowledgements

We thank Kouji Urushihara for technical support. Portions of the data were presented at the 14th annual meeting of the Spanish Society of Comparative Psychology, Seville, September 2002. The second author is now at Graduate School for Special Education Studies, Tsukuba University, Japan. This research was supported by a Grant-in-Aid for Scientific Research in Academic Frontier Promotion Project provided by the Japanese Ministry of Education, Culture, Sports, and Technology. We are grateful to anonymous reviewers for their valuable comments on the manuscript.

References

- Aguado, L., Symonds, M., Hall, G., 1994. Interval between preexposure and test determines the magnitude of latent inhibition: implications for an interference account. *Anim. Learn. Behav.* 22, 188–194.
- Baker, A.G., Mackintosh, N.J., 1977. Excitatory and inhibitory conditioning following uncorrelated presentations of CS and UCS. *Anim. Learn. Behav.* 5, 315–319.
- Baker, A.G., Mercier, P., 1982. Extinction of the context and latent inhibition. *Learn. Motiv.* 13, 391–416.
- Blaisdell, A.P., Bristol, A.S., Gunther, L.M., Miller, R.R., 1998. Overshadowing and latent inhibition counteract each other: support for the comparator hypothesis. *J. Exp. Psychol. Anim. Behav. Proc.* 24, 335–351.
- Blaisdell, A.P., Savastano, H.I., Miller, R.R., 1999. Overshadowing of explicitly unpaired conditioned inhibition is disrupted by preexposure to the overshadowing inhibitor. *Anim. Learn. Behav.* 27, 346–357.
- Bouton, M.E., 1991. Context and retrieval in extinction and in other examples of interference in simple associative learning. In: Dachowski, L., Flaherty, C.F. (Eds.), *Current Topics in Animal Learning: Brain, Emotion, and Cognition*. Erlbaum, Hillsdale, NJ, pp. 25–53.
- Bouton, M.E., 1993. Context, time, and memory retrieval in the interference paradigms of Pavlovian learning. *Psychol. Bull.* 114, 80–99.
- Channell, S., Hall, G., 1983. Contextual effects in latent inhibition with an appetitive conditioning procedure. *Anim. Learn. Behav.* 11, 67–74.
- Denniston, J.C., Savastano, H.I., Miller, R.R., 2001. The extended comparator hypothesis: learning by contiguity, responding by relative strength. In: Mowrer, R.R., Klein, S.B. (Eds.), *Handbook of Contemporary Learning Theories*. Erlbaum, Mahwah, NJ, pp. 65–117.
- Fenwick, S., Mikulka, P.J., Klein, S.B., 1975. The effect of different levels of pre-exposure to sucrose on acquisition and extinction of a conditioned aversion. *Behav. Biol.* 14, 231–235.
- Friedman, B., Blaisdell, A.P., Escobar, M.E., Miller, R.R., 1998. Comparator mechanisms and conditioned inhibition: CS-preexposure disrupts Pavlovian conditioned inhibition but not explicitly unpaired inhibition. *J. Exp. Psychol. Anim. Behav. Proc.* 24, 453–466.
- Hall, G., 1991. *Perceptual and Associative Learning*. Oxford University Press, Oxford.
- Hall, G., Channell, S., 1985. Differential effects of contextual change on latent inhibition and on the habituation of an orienting response. *J. Exp. Psychol. Anim. Behav. Proc.* 11, 470–481.
- Hall, G., Channell, S., 1986. Context-specificity of latent inhibition in taste aversion learning. *Q. J. Exp. Psychol.* 38B, 121–139.
- Hall, G., Honey, R.C., 1989. Contextual effects in conditioning, latent inhibition, and habituation: associative and retrieval functions of contextual cues. *J. Exp. Psychol. Anim. Behav. Proc.* 15, 232–241.
- Hall, G., Minor, H., 1984. A search for context-stimulus associations in latent inhibition. *Q. J. Exp. Psychol.* 36B, 145–169.
- Hall, G., Kaye, H., Pearce, J.M., 1985. Attention and conditioned inhibition. In: Miller, R.R., Spear, N.E. (Eds.), *Information Processing in Animals: Conditioned Inhibition*. Erlbaum, Hillsdale, NJ, pp. 185–207.
- Kaye, H., Preston, G.C., Szabo, L., Druiff, H., Mackintosh, N.J., 1987. Context-specificity of conditioning and latent inhibition: evidence for a dissociation of latent inhibition and associative interference. *Q. J. Exp. Psychol.* 39B, 127–145.
- Kiefer, S.W., Phillips, J.A., Braun, J.J., 1977. Preexposure to conditioned and unconditioned stimuli in taste aversion learning. *Bull. Psychon. Soc.* 10, 226–228.
- Kremer, E.F., 1972. Properties of a preexposed stimulus. *Psychon. Sci.* 27, 45–47.
- Lovibond, P.F., Preston, G.C., Mackintosh, N.J., 1984. Context-specificity of conditioning, extinction, and latent inhibition. *J. Exp. Psychol. Anim. Behav. Proc.* 10, 360–375.
- Lubow, R.E., 1973. Latent inhibition. *Psychol. Bull.* 79, 398–407.
- Lubow, R.E., 1989. *Latent Inhibition and Conditioned Attention Theory*. Cambridge University Press, Cambridge.
- Lubow, R.E., Siebert, L., 1969. Latent inhibition within the CER paradigm. *J. Comp. Physiol. Psychol.* 68, 136–138.
- Lubow, R.E., Weiner, I., Schnur, P., 1981. Conditioned attention theory. In: Bower, G.H. (Ed.), *The Psychology of Learning and Motivation*, vol. 15. Academic Press, New York, pp. 1–49.
- Mackintosh, N.J., 1975. A theory of attention: variations in the associability of stimuli with reinforcement. *Psychol. Rev.* 82, 276–298.
- McLaren, I.P.L., Bennett, C., Plaisted, K., Aitken, M., Mackintosh, N.J., 1994. Latent inhibition, context-specificity, and context familiarity. *Q. J. Exp. Psychol.* 47B, 387–400.
- Miller, R.R., Matzel, L.D., 1988. The comparator hypothesis: a response rule for the expression of associations. In: Bower, G.H. (Ed.), *The Psychology of Learning and Motivation*, vol. 22. Academic Press, San Diego, CA, pp. 51–92.
- Miller, R.R., Schachtman, T.R., 1985. Conditioning context as an associative baseline: implications for response generation and the nature of conditioned inhibition. In: Miller, R.R., Spear, N.E. (Eds.), *Information Processing in Animals: Conditioned Inhibition*. Erlbaum, Hillsdale, NJ, pp. 51–88.
- Nakajima, S., Ka, H., Imada, H., 1999. Summation of overshadowing and latent inhibition in rats' conditioned taste aversion: scapegoat technique works for familiar meals. *Appetite* 33, 299–307.
- Nakajima, S., Tanaka, S., Urushihara, K., Imada, H., 2000. Renewal of extinguished lever-press responses upon return to the training context. *Learn. Motiv.* 31, 416–431.
- Pearce, J.M., Hall, G., 1980. A model for Pavlovian learning: variations in the effectiveness of conditioned but not of unconditioned stimuli. *Psychol. Rev.* 87, 532–552.
- Reed, P., 1991. Blocking latent inhibition. *Bull. Psychon. Soc.* 29, 292–294.
- Reed, P., 1995. Enhanced latent inhibition following compound pre-exposure. *Q. J. Exp. Psychol.* 48B, 32–45.

- Reiss, S., Wagner, A.R., 1972. CS habituation produces a “latent inhibition effect” but not active “conditioned inhibition”. *Learn. Motiv.* 3, 237–245.
- Rescorla, R.A., 1971. Summation and retardation tests of latent inhibition. *J. Comp. Physiol. Psychol.* 75, 77–81.
- Revusky, S.H., Bedarf, E.W., 1967. Association of illness with prior ingestion of novel food. *Science* 155, 219–220.
- Rosas, J.M., Bouton, M.E., 1997. Additivity of the effects of retention interval and context change on latent inhibition: toward resolution of the context forgetting paradox. *J. Exp. Psychol. Anim. Behav. Proc.* 23, 283–294.
- Siegel, S., 1974. Flavor preexposure and “learned safety”. *J. Comp. Physiol. Psychol.* 87, 1073–1082.
- Wagner, A.R., 1976. Priming in STM: an information-processing mechanism for self-generated or retrieval-generated depression in performance. In: Tige, T.J., Leaton, R.N. (Eds.), *Habituation: Perspectives from Child Development, Animal Behavior, and Neurophysiology*. Erlbaum, Hillsdale, NJ, pp. 95–128.
- Wagner, A.R., 1981. SOP: a model of automatic memory processing in animal behavior. In: Spear, N.E., Miller, R.R. (Eds.), *Information Processing in Animals: Memory Mechanisms*. Erlbaum, Hillsdale, NJ, pp. 5–47.
- Weiss, K.R., Brown, B.L., 1974. Latent inhibition: a review and a new hypothesis. *Acta Neurobiol. Exp.* 34, 301–316.